

SPECK® BADU® Eco Touch VS

The **8-STAR RATED** pump now with a variable speed circulation delivers serious power AND serious savings

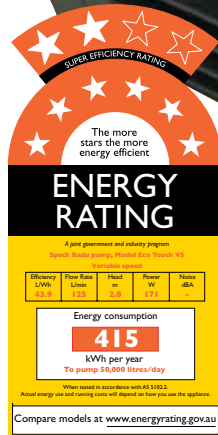

8-Star Energy Rating for
Ultimate Energy Savings

Lower Noise Levels

Lower Carbon Footprint

German Design & Engineering



Pool Products for Pure Enjoyment

SPECK® BADU® Eco Touch VS

The new, BADU Eco Touch VS pump is cutting edge motor technology which is revolutionising energy efficiency by lowering power consumption and operating costs while increasing water quality in pools and spas.

Thanks to its 8 Star energy rating, the highly efficient BADU Eco Touch VS is setting the standard compared with a conventional induction motor pump. The operating costs and the CO² emissions are significantly lower in comparison with a standard pump meaning the pump pays for itself in less than two years!

- Patented permanent magnet motor, with axil rotor, referred to as EC Motor, perfected for use in swimming pools and spa filter systems
- For pool and spas from 30m³ to 70m³
- Speed 1 (low) for night time operation
- Improved speed control at Speed 2 (medium) delivers improved water quality
- Speed 3 (high) for filter backwashing
- Pre-set stages always provide optimal performance for power savings
- Simple and brilliant – the lower the motor speed the lower the energy consumption
- Settings can be selected using a user-friendly control panel
- Separate interface to allow for external touch free control
- Designed for quiet operation
- dBa ratings at 1m 52.5dB
- Stainless steel shaft and 100% recyclable plastics for corrosion and salt water resistance
- Motor double sealed for total separation between the pool water and pump shaft
- Suitable for pools with a maximum salt level of 5,000 ppm

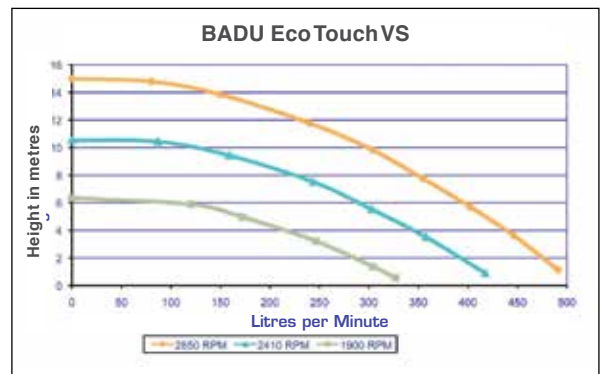
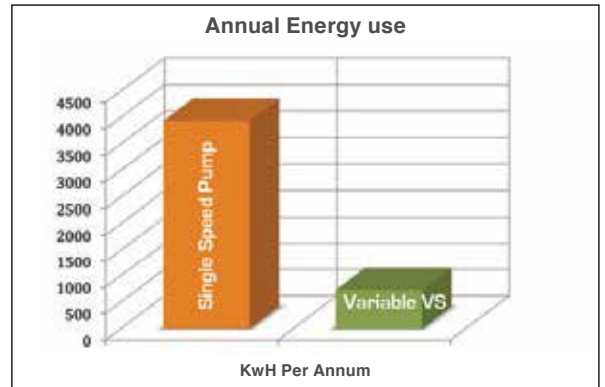
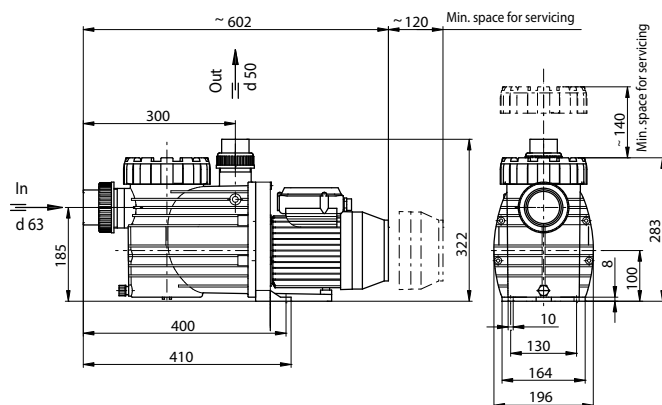

	Eco Touch VS
Head Max/Min - m	15/1
Inlet Connection - mm	50
Outlet Connection - mm	40
Motor Speed - RPM	Adjustable
Power Input - V	240
Power Output - Kw	750
AMPS	6.5
Weight - kg	11
Max Water Temp - Deg.C	35

WARRANTY

Five (5) year Factory Warranty on the following wet end components: Casing, Diffuser, Gland Housing, Impeller and Mechanical Seal. Two (2) year warranty on motor and in all commercial applications. The pouring of salt and chemicals directly into the skimmer box will void full warranty.



1300 166 253 for Sales and Service

e sales@continentalwater.com.au / accounts@continentalwater.com.au ABN: 71 050 287 735

New South Wales Office
t (02) 8814 2800
f (02) 9838 7030

Victorian Office
t (03) 8794 3800
f (03) 9702 3941

Queensland Office
t (07) 3434 1100
f (07) 3219 2266

New Zealand Office
t 0011 64 9570 9570
f 0015 64 9527 7641